

Insulated Gate Bipolar Transistor 1200V 50A 278W TO-247

MIG120N50T247

MERITEK

FEATURE

- Trench Gate and Field Stop Processes IGBT
- Low Saturation Collector-to-Emitter Voltage and High Switching Speed
- Positive Saturation Collector-to-Emitter Voltage Temperature Coefficient
- Soft and Fast Recover Antiparallel Diode
- 10µs of Short - Circuit Withstand Time

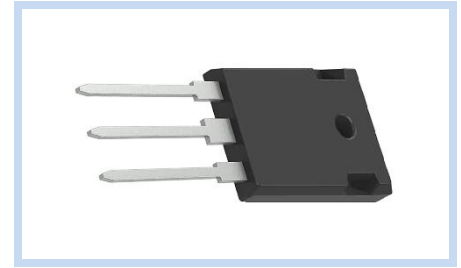

MECHANICAL DATA

- Case: TO-247 Package
- Terminals: Solderable per MIL-STD-750, Method 2026

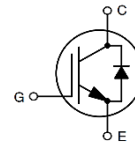

MAXIMUM RATINGS

Parameter	Symbol	Value	Unit
Collector-to-Emitter Breakdown Voltage	V_{CES}	1200	V
Gate-to-Emitter Voltage	V_{GE}	±30	V
Collector Current – Continuous	I_C	$T_C=25^{\circ}C$	50
		$T_C=100^{\circ}C$	25
Collector Current – Pulsed	I_{CM}	75	A
Maximum Power Dissipation	P_D	$T_C=25^{\circ}C$	278
		$T_C=100^{\circ}C$	110
Thermal Resistance Junction to Ambient	$R_{\theta JA}$	40	$^{\circ}C/W$
Thermal Resistance Junction to Case For IGBT	$R_{\theta JC}$	0.45	$^{\circ}C/W$
Operating Junction and Storage Temperature Range	T_J, T_{STG}	-55 to 150	$^{\circ}C$

ELECTRICAL CHARACTERISTICS

Static Characteristics	Conditions	Symbol	Min	Typ.	Max	Unit
Collector-Emitter Breakdown Voltage	$V_{GE}=0V, I_C=1mA$	BV_{CES}	1200	--	--	V
Zero Gate Voltage Collector Current	$V_{CS}=1200V, V_{GE}=0V$	I_{CES}	--	--	1	μA
Gate-Body Leakage Current, Forward	$V_{GE}=30V, V_{CS}=0V$	I_{GESF}	--	--	200	nA
Gate-Body Leakage Current, Reverse	$V_{GE}=-30V, V_{CS}=0V$	I_{GESR}	--	--	-200	nA
Collector-Emitter Saturation Voltage	$V_{GE}=15V, I_C=25A$	$V_{CE(SAT)}$	--	1.95	2.5	V
Gate Threshold Voltage	$V_{GE}=V_{DS}, I_C=1mA$	$V_{GE(th)}$	5	--	7	V
Diode Forward Voltage	$I_F=25A$	V_F	--	2.4	3	V
Dynamic Characteristics	Conditions	Symbol	Min	Typ.	Max	Unit
Total Gate Charge	$V_{CC}=1080V, V_{GE}=15V, I_C=20A$	Q_g	--	135	--	nC
Gate-Emitter Charge		Q_{ge}	--	27	--	
Gate-Collector Charge		Q_{gc}	--	66	--	
Input Capacitance	$V_{CE}=25V, V_{GE}=0V, F=1MHz$	C_{ies}	--	3402	--	pF
Output Capacitance		C_{oes}	--	96	--	
Reverse Transfer Capacitance		C_{res}	--	52	--	
Switching Characteristics	Conditions	Symbol	Min	Typ.	Max	Unit
Turn-On Delay Time	$V_{CC}=600V, V_{GE}=15V, R_G=10\Omega$ $I_C=20A, T_C=25^{\circ}C,$ Inductive Load	$T_{d(on)}$	--	50	--	ns
Rise Time		T_r	--	54	--	
Turn-Off Delay Time		$T_{d(off)}$	--	184	--	
Fall Time		T_f	--	179	--	mJ
Turn-On Switching Loss		E_{on}	--	1.02	--	
Turn-Off Switching Loss		E_{off}	--	1.01	--	
Reverse Recovery Time	$I_F=20A, di_F/dt = 100A/\mu s$	t_{rr}	--	76	--	ns
Reverse Recovery Charge		Q_{rr}	--	0.48	--	μC
Peak Reverse Recovery Current		I_{rr}	--	10	--	A

Note: 1. $T_C = 25^{\circ}C$ unless otherwise noted. 2. Pulse width < 300µs, Duty cycle < 2%

Insulated Gate Bipolar Transistor

1200V 50A 278W TO-247

MIG120N50T247

MERITEK

CHARACTERISTIC CURVES

Output Characteristics

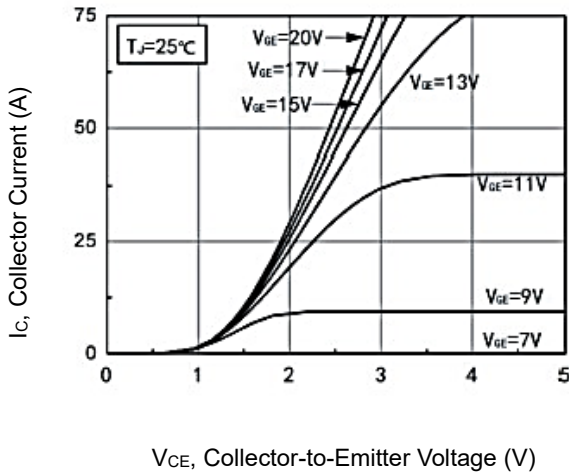

Output Characteristics

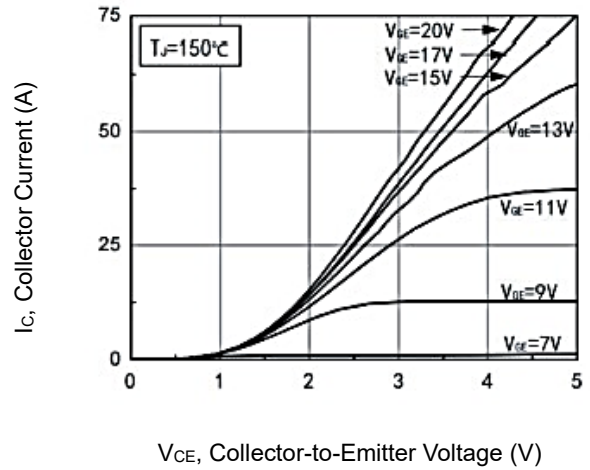

Transfer Characteristics

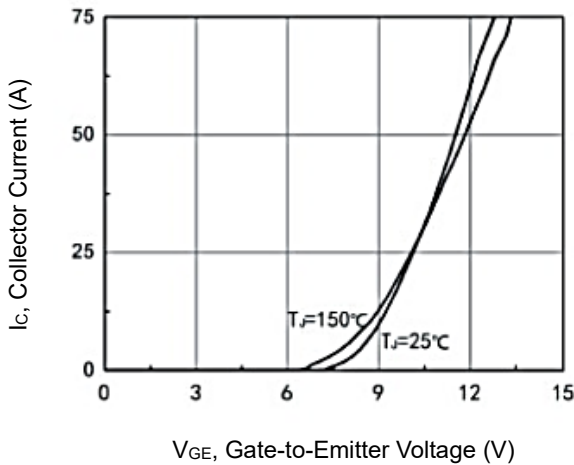

Diode Forward Characteristics

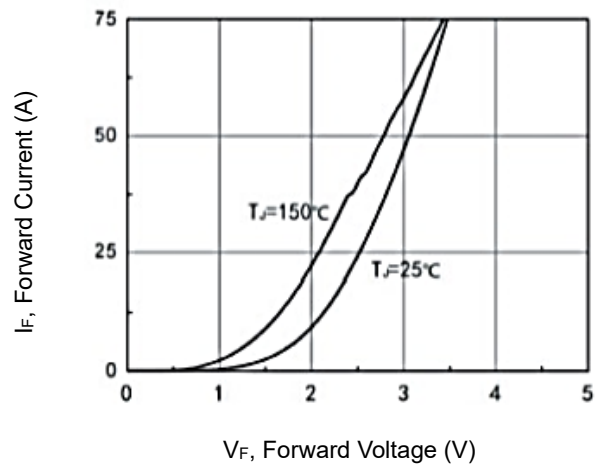

Forward Voltage Variation

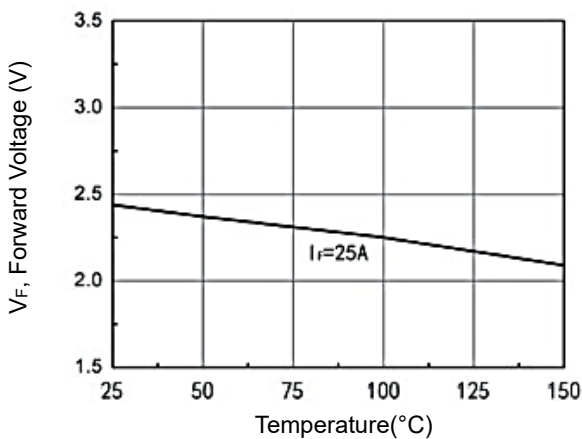

Collector-Emitter Saturation Voltage

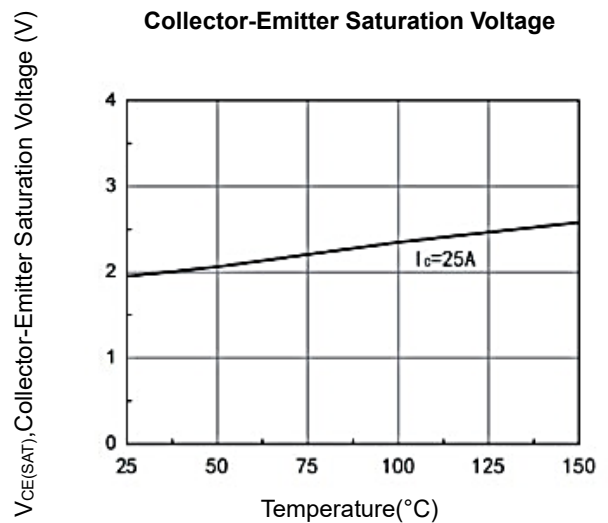

Insulated Gate Bipolar Transistor 1200V 50A 278W TO-247

MIG120N50T247

MERITEK

CHARACTERISTIC CURVES

Gate Threshold Voltage Variation

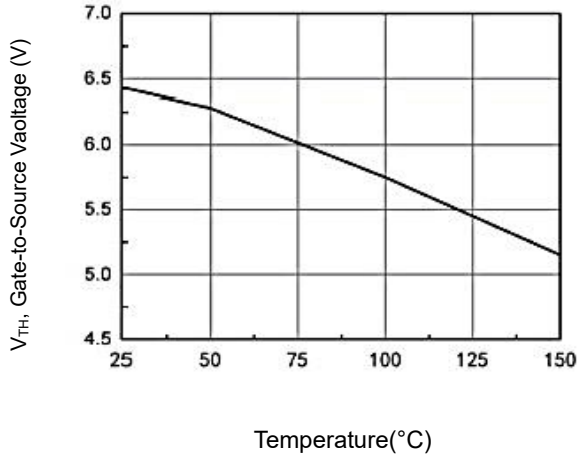

Capacitance Characteristics

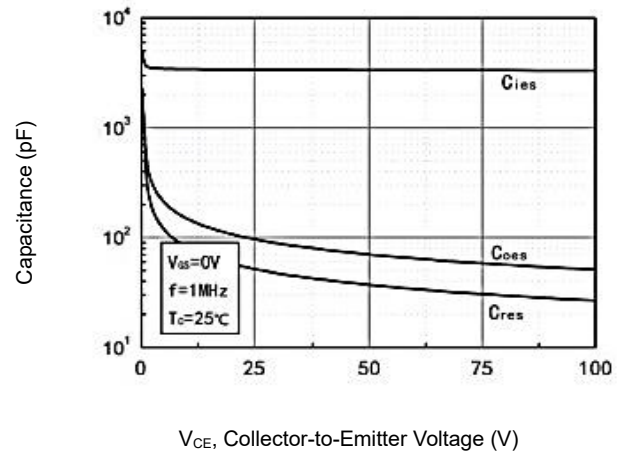

Gate-Charge Characteristics

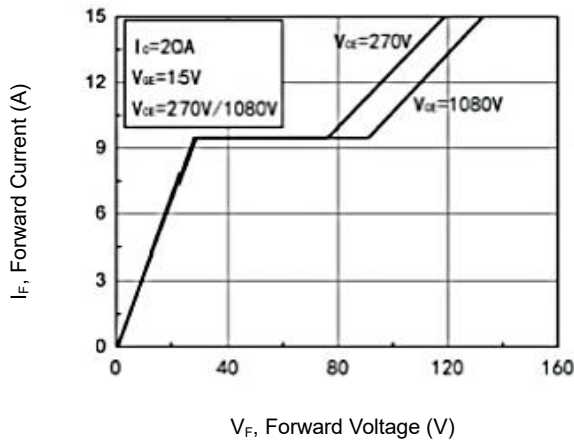

Forward Bias Safe Operating Area

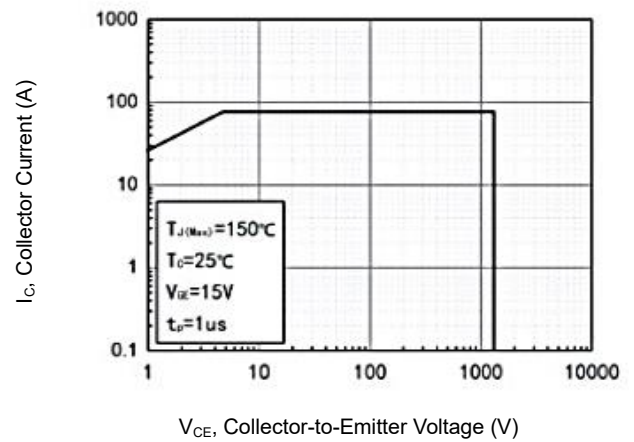

Switching Energy Loss vs Gate Resistances

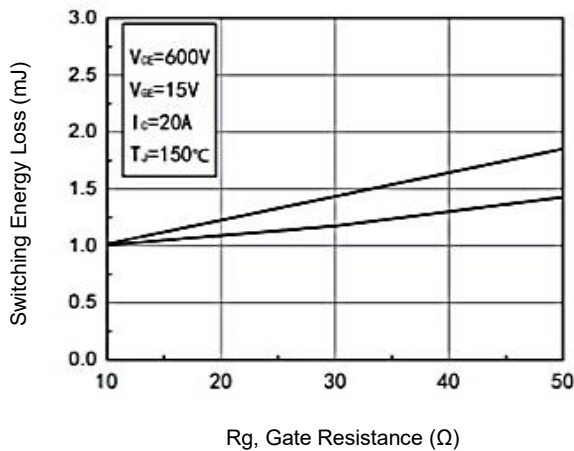

Transient Thermal Resistance

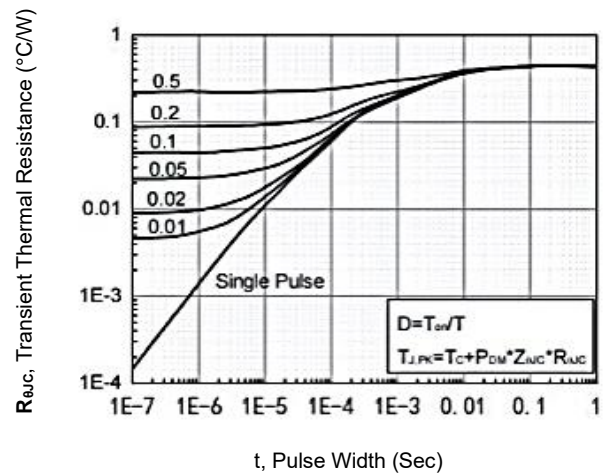

Insulated Gate Bipolar Transistor 1200V 50A 278W TO-247

MIG120N50T247

MERITEK

DIMENSIONS

TO-247	Min	Max
A	4.60	5.20
A1	1.90	2.16
A2	2.20	2.60
b	0.90	1.40
b1	2.80	3.35
b2	1.75	2.15
c	0.50	0.70
D	20.60	21.30
D1	16.35	16.75
e	5.45	
e1	5.45	
E	15.50	16.10
E1	13.10	13.40
E2	3.80	5.30
L	19.00	20.50
L1	3.90	4.60
p	3.30	3.70
p1	6.90	7.30
Q	5.20	6.00
S	5.20	6.00

Note: 1: Gate(G), 2: Collector(C), 3: Emitter (E).

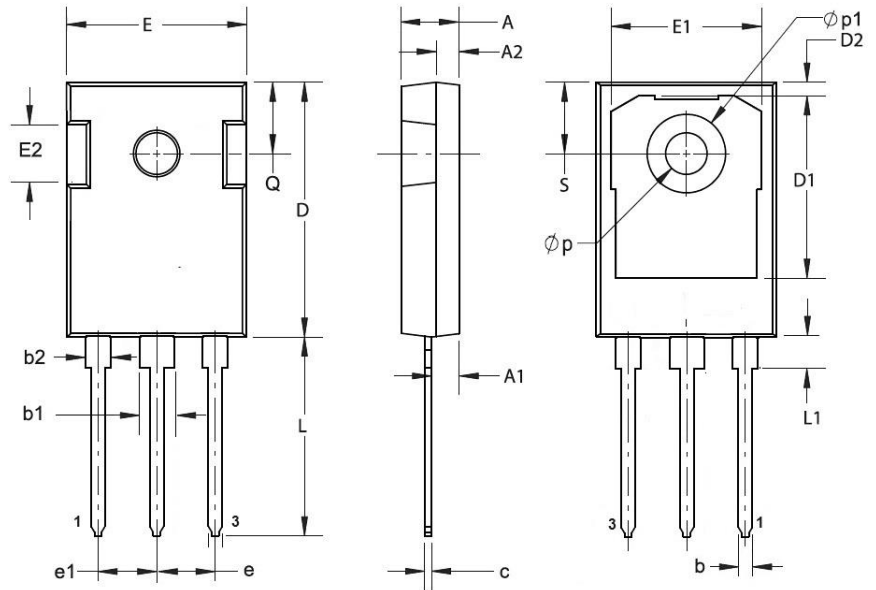

TEST CONDITION

Switching Time Waveform

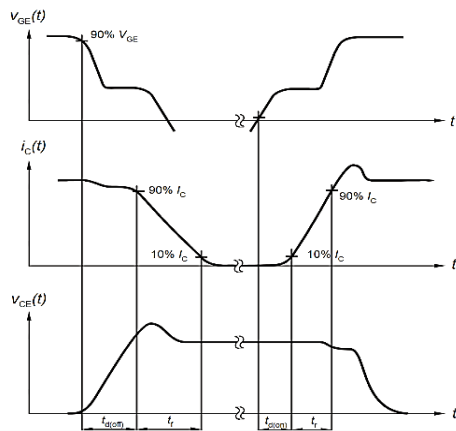

Switching Test Circuit

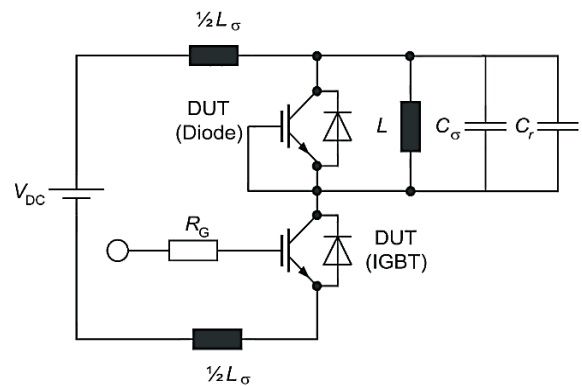

Switching Losses Waveform

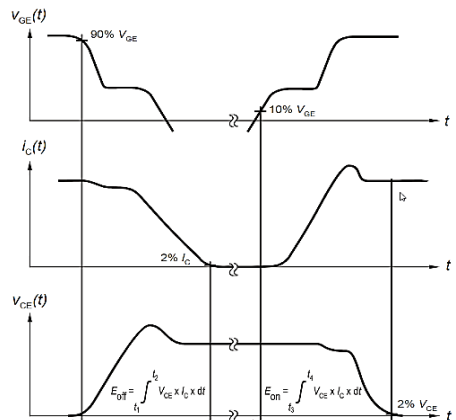

Diode Switching Characteristics

