

N-Channel MOSFET

200V 40A 220W TO-220

MFT20N40T220

MERITEK

FEATURE

- $R_{DS(ON)} < 41m\Omega$ at $V_{GS}=10V$, $I_D=20A$
- High Power and Current Handling Capability
- Fully Characterized Avalanche Voltage and Current
- High Dense Cell Design for Ultra Low $R_{DS(ON)}$
- Application: Power Switching, Hard Switched and High Frequency Circuits, Uninterruptible Power Supply

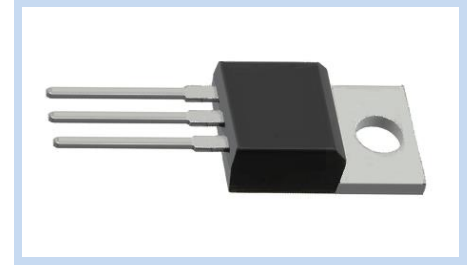

MECHANICAL DATA

- Case: TO-220 Package
- Terminals: Solderable per MIL-STD-750, Method 2026

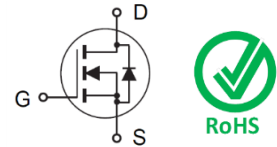

MAXIMUM RATINGS

Parameter	Symbol	Value	Unit
Drain-Source Voltage	V_{DS}	200	V
Gate-Source Voltage	V_{GS}	± 20	V
Drain Current – Continuous	I_D	40	A
Drain Current – Pulsed	I_{DM}	160	A
Power Dissipation	P_D	220	W
Single Pulsed Avalanche Energy	E_{AS}	480	mJ
Thermal Resistance Junction to Case	$R_{\theta JC}$	0.68	$^{\circ}C/W$
Junction Temperature	T_J	150	$^{\circ}C$
Storage Temperature Range	T_{STG}	-55 to 150	$^{\circ}C$

DIMENSIONS

Unit: mm

Item	Min	Max
A	4.40	4.60
A1	1.20	1.40
A2	2.25	2.55
b	0.71	0.91
b2	1.17	1.37
c	0.33	0.65
D	15.50	15.70
E	9.91	10.25
e1	4.98	5.18
L	12.90	13.40
L1	2.85	3.25
Q	2.65	2.95
P	3.40	3.80

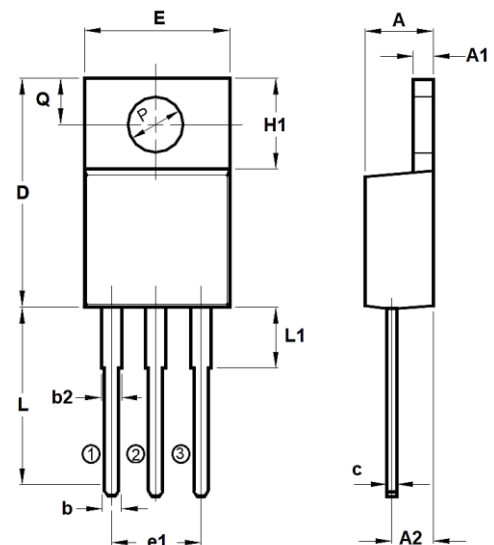

N-Channel MOSFET

200V 40A 220W TO-220

MFT20N40T220

MERITEK

ELECTRICAL CHARACTERISTICS

Off Characteristics	Conditions	Symbol	Min	Typ.	Max	Unit
Drain-Source Breakdown Voltage	$V_{GS}=0V, I_D=250\mu A$	BV_{DSS}	200	--	--	V
Drain-Source Leakage Current	$V_{DS}=200V, V_{GS}=0V$	I_{DSS}	--	--	1	μA
Gate-Body Leakage Current	$V_{GS}=\pm 20V, V_{DS}=0V$	I_{GSS}	--	--	± 100	nA
On Characteristics	Conditions	Symbol	Min	Typ.	Max	Unit
Static Drain-Source On-Resistance	$V_{GS}=10V, I_D=20A$	$R_{DS(ON)}$	--	--	41	m Ω
Gate Threshold Voltage	$V_{GS}=V_{DS}, I_D=250\mu A$	$V_{GS(th)}$	2	--	4	V
Forward transconductance	$V_{DS}=25V, I_D=250\mu A$	G_{FS}	26			S
Dynamic Characteristics	Conditions	Symbol	Min	Typ.	Max	Unit
Total Gate Charge	$V_{DS}=30V, V_{GS}=10V, I_D=30A$	Q_g	--	163	--	nC
Gate-Source Charge		Q_{gs}	--	31	--	
Gate-Drain Charge		Q_{gd}	--	64	--	
Turn-On Delay Time	$V_{DD}=30V, V_{GS}=10V, R_G=2.5\Omega, R_L=15\Omega, I_D=2A$	$T_{d(on)}$	--	26	--	ns
Rise Time		T_r	--	24	--	
Turn-Off Delay Time		$T_{d(off)}$	--	91	--	
Fall Time		T_f	--	39	--	
Input Capacitance	$V_{DS}=25V, V_{GS}=0V, F=1MHz$	C_{iss}	--	6500	--	pF
Output Capacitance		C_{oss}	--	290	--	
Reverse Transfer Capacitance		C_{rss}	--	220	--	
Drain-Source Body Diode	Conditions	Symbol	Min	Typ.	Max	Unit
Drain-Source Diode Forward Current	--	I_S	--	--	40	A
Diode Forward Voltage	$V_{GS}=0V, I_S=40A$	V_{SD}	--	--	1.2	V
Reverse Recovery Time	$I_F=40A, T_J=25^\circ C, di/dt=100A/\mu s$	T_{rr}	--	42	--	ns
Reverse Recovery Charge		Q_{rr}	--	66	--	nC

Note:

- $T_A=25^\circ C$, unless otherwise noted
- Pulse Test: Pulse Width $\leq 300\mu s$, Duty Cycle $\leq 2\%$
- Guaranteed by design, not subject to production testing.

Switching Time Waveform

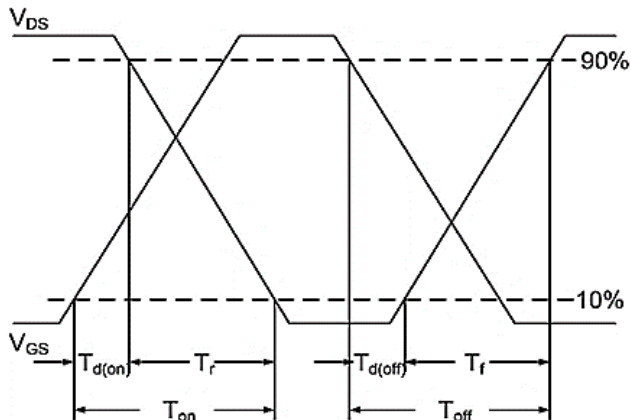

Switching Test Circuit

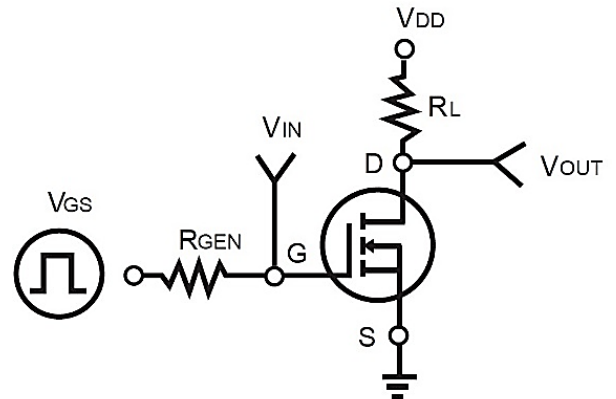

N-Channel MOSFET

200V 40A 220W TO-220

MFT20N40T220

MERITEK

CHARACTERISTIC CURVES

Output Characteristics

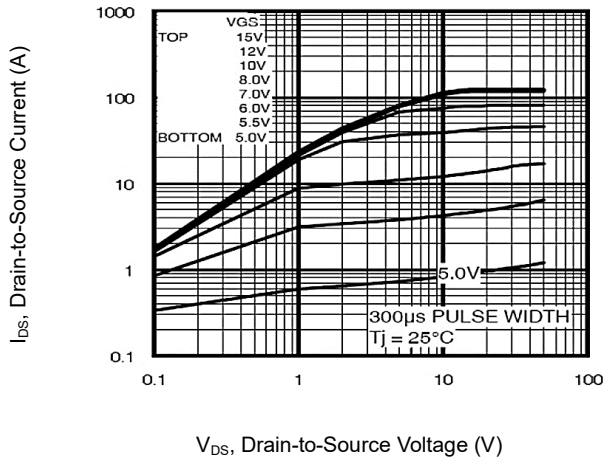

Transfer Characteristics

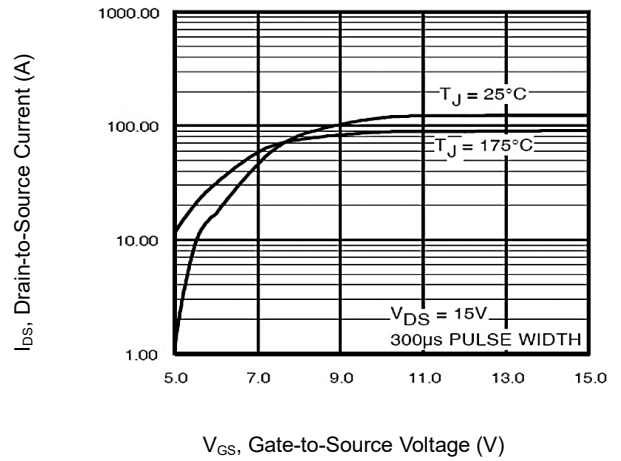

Breakdown Voltage vs. Temperature

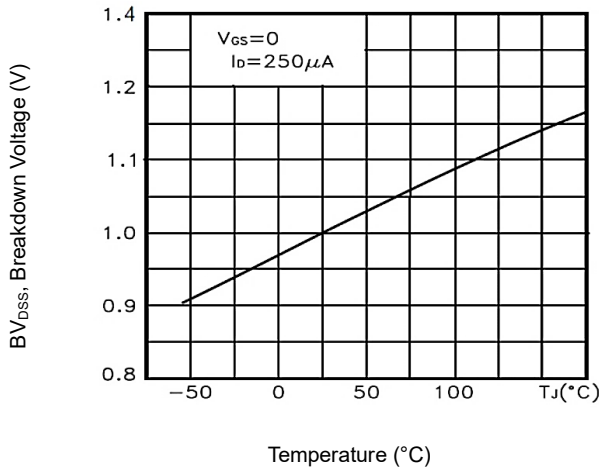

On-Resistance vs. Junction temperature

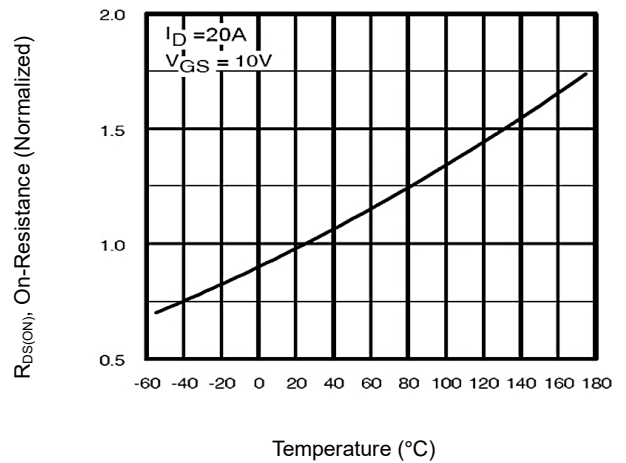

On-Resistance vs Drain Current

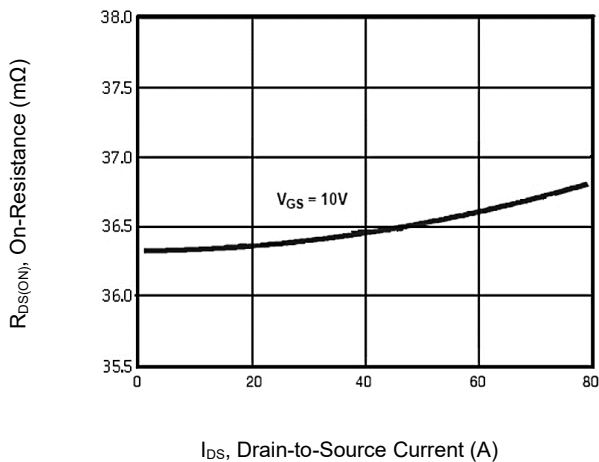

Body Diode Characteristics

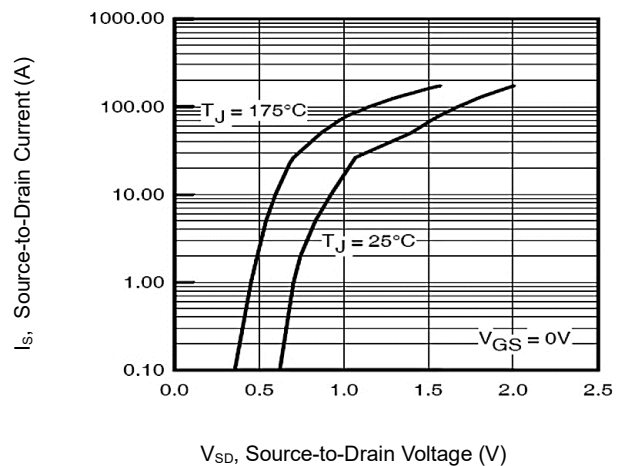

N-Channel MOSFET

200V 40A 220W TO-220

MFT20N40T220

MERITEK

CHARACTERISTIC CURVES

Gate-Charge Characteristics

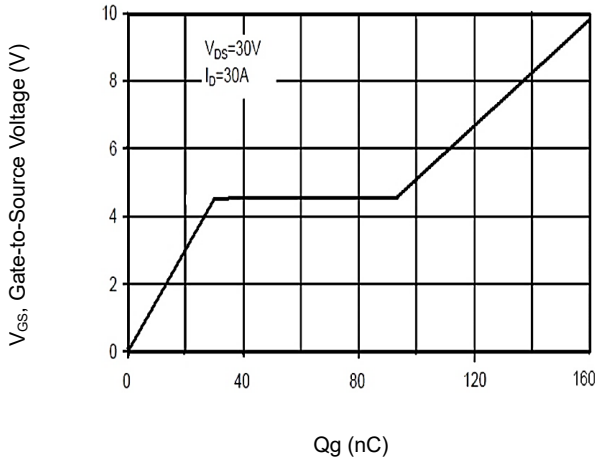

Capacitance vs. Drain-Source Voltage

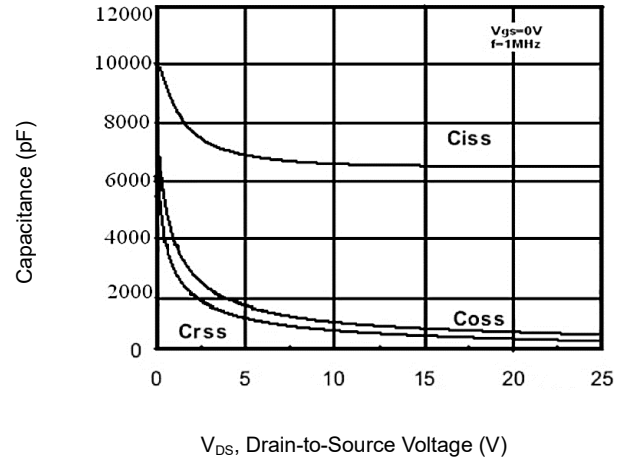

Maximum Safe Operating Area

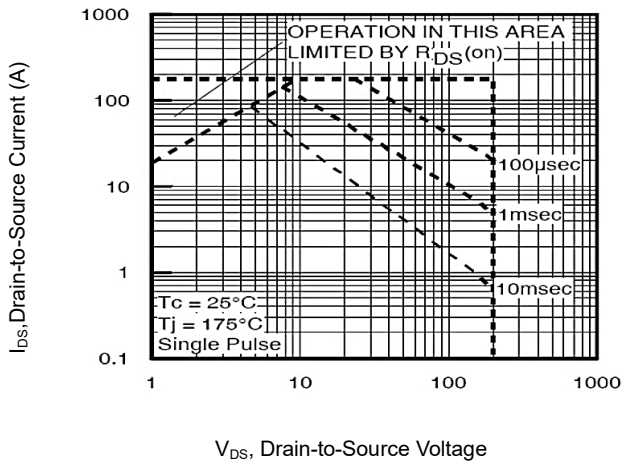

Threshold Voltage Variance

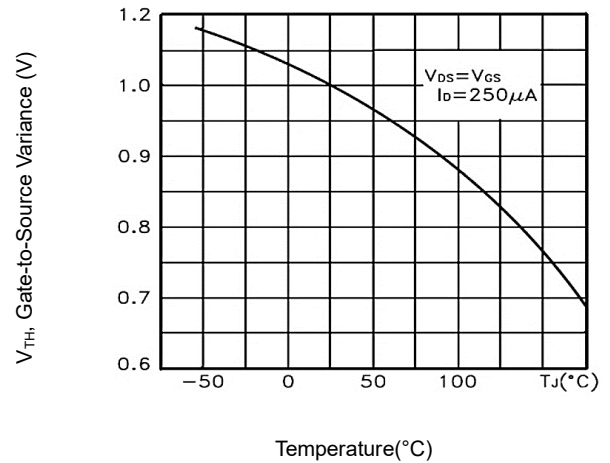

Normalized Transient Thermal Impedance vs Pulse Width

